

TriLane tripod turnstiles are designed for dissuasive and economical access control and allow the fixing of control equipment such as: proximity scanners, bar code scanners, badge collectors, facial recognition cameras, etc.

Their mechanisms, of robust and reliable design, exist in various configurations covering all most likely encountered cases in terms of pedestrian access control.

The TriLane mechanism includes, as an option, an anti-panic device that automatically releases the tripod arm in the event of a power failure. The unobstructed access then allows uninterrupted passage for users. The arm must be reset manually or by means of the optional motorisation when the power supply is restored.

TriLane turnstiles can be installed indoors or outdoors, alone or in battery. It can be combined with an AccessLane gate to generate a passageway for people with reduced mobility.

PRODUCT DESCRIPTION

1. Self-supporting painted steel body.
2. Front panel in painted steel, locked by 2 locks to access to electronic and connection terminals
3. Removable top cover, in stainless steel locked with a key, to access the tripod mechanism.
4. Tripod mechanism and its casing in painted steel : the locking of the tripod rotation is ensured by electromagnets and locking cams. Depending on the mode selected, an anti-return device prevents reverse rotation. (*Unidirectional control as standard and bidirectional control as option*).
5. Arm in stainless steel AISI 304.
6. Electronic control logic AS1635.
7. Optional function pictogram.

CONVENTIONS

Direction A = housing at right hand side of the walkway.

Direction B = housing at left hand side of the walkway.

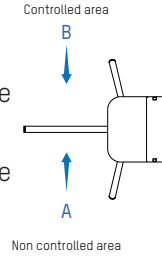

WORKING MODES

The **TriLane** turnstile can operate in 5 different modes for each passage direction.

1. Access permanently free.
2. Access permanently mechanically locked.
3. Access mechanically locked with automatic unlocking device to allow free passage in case of power failure. (*Free-rotation*).
4. Electrically controlled access.
5. Access electrically controlled with automatic unlocking device to give free passage in case of power failure. (*Free-rotation*).



The standard configuration of the TriLane is A5 - B1.

STANDARD TECHNICAL SPECIFICATIONS

- Power supply : 100 - 230V single phase, 50/60 Hz.
- Control circuit : 24V DC.
- Electromagnet: duty cycle 30%.
- Nominal consumption: max. 20W.
- Ambient operating temperature: from -10° to + 50° C.
- Flow: 20 passages/minute.
- MCBF (*Mean Cycles Between Failures*), when respecting recommended maintenance: 5,000,000.
- This equipement is IP44.
- EC compliant.
- Net weight: 46 kg.

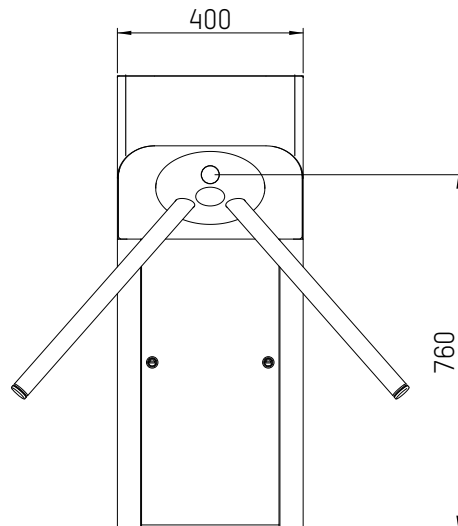

OPTIONAL

1. Dropping arm.
2. Arm length of 550 mm.
3. Bidirectional passage.
4. Function pictogram (*both directions*).
5. Function pictogram + kit for reader integration (*both directions*).
6. Full AISI 304L stainless steel housing.
7. Arm movement damping system.
8. Network connectivity (IP).
9. Paint in : RAL5008, RAL6014, RAL7003, RAL7016, RAL9010.
10. Thermostated heating (*for operation until -20°C*).

ANTI CORROSION TREATMENT

All internal parts are treated by zinc coating and passivation.

WORK TO BE PROVIDED BY THE CUSTOMER

- Power supply.
- Connecting electrical wiring to the control units.
- Potential masonry and fixing work (*see installation drawing*).

STANDARD DIMENSIONS (mm)

