

# AL 933

## Technical datasheet

AL 933-FT-EN-00

**AUTOMATIC**  
SYSTEMS

Access controlled...  
Future secured

## AccessLane

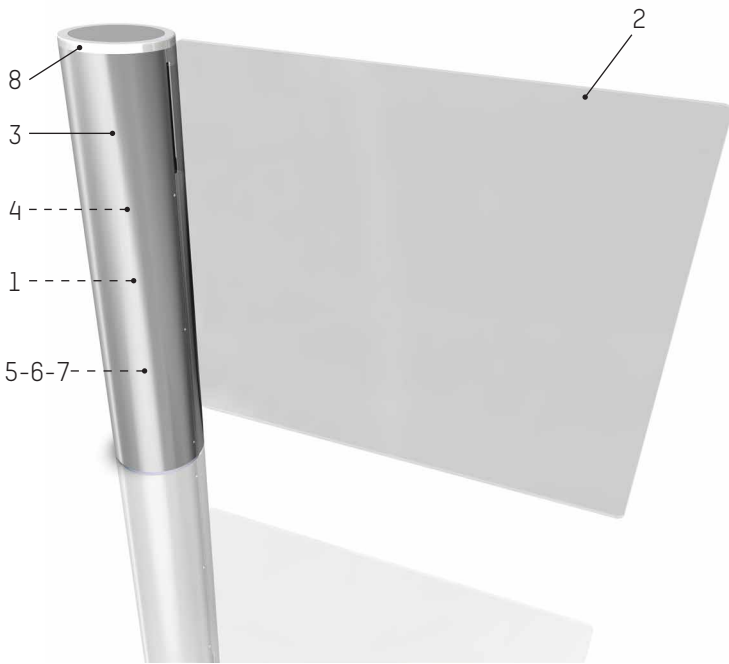

Designed for use in intra-building sites, the AL 933 swing gate facilitates the passage of people with reduced mobility (wheelchair users, service staff with trolleys, bulky equipment, etc.) as well as the evacuation of the building in an emergency.

Its discreet design makes it particularly suitable for access control in prestigious access areas.

Since the gate is bi-directional, the obstacle opens in the user's direction of passage.

Possible configurations:

- alone, facing a wall or a guardrail,
- facing each other (independent operation),
- facing each other (simultaneous operation),
- in conjunction with security entrance lanes or turnstiles.

### DESCRIPTION

1. Steel central pillar with RoHS anti-corrosion zinc plating treatment, fixed to the floor by means of an adjustable base allowing easy levelling.
2. Passage obstacle in 10mm clear toughened glass.
3. AISI 304 brushed stainless steel, folded and welded panels for easy access to the electromechanical unit and the control logic unit.
4. Electromechanical drive for operation of the obstacle, consisting of:
  - a *brushless* motor coupled to a planetary gearbox;
  - an encoder;
  - a power supply board controlled by the control logic unit.
5. Electronic control logic using the ARM Cortex A8 technology and the Linux operating system, for advanced system control.  
A built-in Web server accessible from any standard Web browser, provides a simple interface for configuration of the gate's functional parameters and a complete diagnostics and maintenance tool.  
The maintenance interface is common to multiple Automatic Systems products and greatly facilitates product maintenance.
6. Data transfer with the outside world via the XML-RPC protocol over an Ethernet interface.  
The AccessLane can also be controlled from the Smart & Slim operator console.
7. Data transfer by dry contacts: passage authorisation, passage data, fraud, technical defect, etc.
8. Function pictograms indicating gate and passage status to the user.

## OPERATION

The gate is activated by an impulse from an access control system such as a push-button, a motion detector or a card reader installed on a support post, or from a remote program selector located in the reception area.

After passage authorisation, the gate opens automatically (in the user's direction) or by means of a light push, depending on the selected mode. The opening angle is adjustable. The obstacle remains open and closes automatically after a pre-set time.

The opening and closing speeds can be adjusted to meet local requirements.

If the gate is obstructed while rotating, it will stop immediately and make successive attempts to complete the cycle.

If the last attempt is still unsuccessful, the timeout between two attempts will be increased to prevent overheating and the system will be restarted as soon as possible.

A Fire Detection command enables immediate opening of the gate (selectable direction of opening).

In case of a power failure, the gate unlocks and can be opened by a light push.

## STANDARD TECHNICAL CHARACTERISTICS

Power supply	Single phase 110 VAC (1A)-240 VAC (0.5A) (+/- 10%) - 50/60 Hz + Ground. <b>Note:</b> not to be connected to a floating network or to a high impedance earthed industrial distribution network.
Power consumption	15 W during operation (< 10 W at rest)
Peak current	< 1 A
Leakage current	< 3,5 mA
Motor	24 VDC - output power 30 W.
Free passage [L]	1050 mm.
Min. opening/closing time	4 seconds <i>(depending on the access control system reactivity and the user speed)</i>
Operating temperature:	-10° to +50°C.
Relative humidity	< 95%, without condensation
MCBF	1,000,000 mean cycles between failures, in compliance with recommended maintenance.
Sound level	55 dB at 1m.
Weight	55 kg (without obstacle).
Protection rating	IP44.
<b>CE</b>	Complies with European standards.

## OPTIONS

1. Obstacle height: 900 or 1200 mm from the ground.
2. Support post for integration of customer peripheral equipment.
3. Support post with push-button *(for free entrance or exit)*.
4. Support post with motion detector.
5. Monitoring panel.
6. Personalised logo sticker (sanded).
7. Master/Slave configuration.

**Note:** for restrictions regarding the options, refer to the unit type.

## WORK TO BE CARRIED OUT BY THE CUSTOMER

- Floor mounting.
- Power supply.
- Wiring between lanes of a single group.
- Wiring to external peripheral equipment, if any.
- Integration of accessories.

**Note:** Please follow the installation plan.

## STANDARD DIMENSIONS (mm)

